

# STEAMIST®

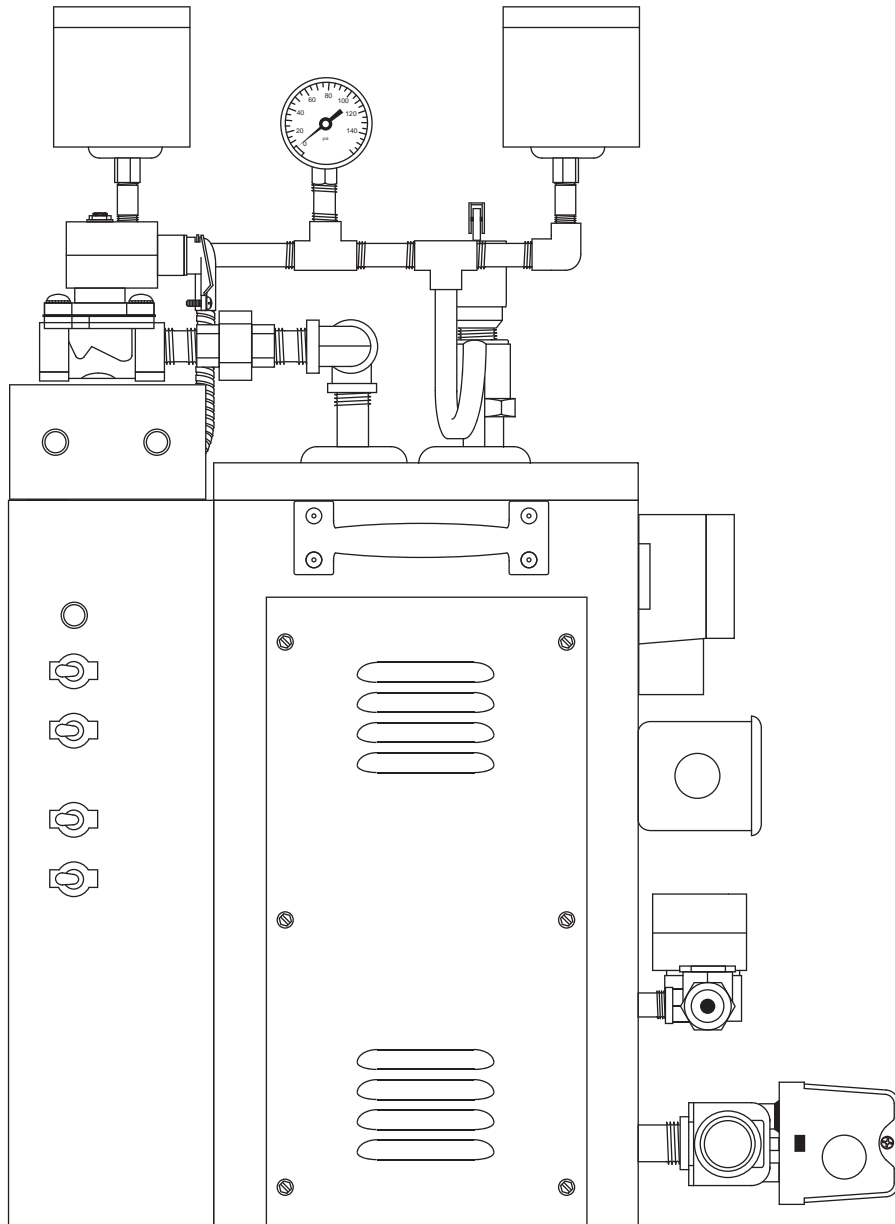

Heavy Commercial Steambath Generator

Models: HC-9 thru HC-18





## Table of Contents

	<i>Page</i>
I. <i>Important Steam bath Safety Guidelines.....</i>	4
II. <i>Warning Sign Installation.....</i>	4
III. <i>Pre-Installation.....</i>	5
IV. <i>Rough-In.....</i>	6
V. <i>Installation.....</i>	7
VI. <i>Digital Command Center Installation.....</i>	8
VII. <i>Digital Commercial Control Package Operation.....</i>	9
VIII. <i>Warranty information.....</i>	16

## List of Illustrations

	<i>Page</i>
<i>Warning Sign.....</i>	4
<i>Figure 1 - Dimensional Drawing for Heavy Commercial Steam Generator (HC-9 thru HC-18).....</i>	5
<i>Figure 2 - Cables.....</i>	6
<i>Figure 3 - Typical Steam Generator Installation.....</i>	6
<i>Figure 4 - Sensor Installation (Inside Steam Room).....</i>	8
<i>Figure 5 - User Control Panel.....</i>	9
<i>Figure 6 - Main Control Panel.....</i>	10
<i>Programming Examples.....</i>	11
<i>Specifications Chart.....</i>	13
<i>Wiring Diagram.....</i>	14

**I. Important Steam Bath Safety Guidelines:**

- A) Do not permit children to use the steam bath unless they are closely supervised at all times.
- B) Wet surfaces of the steam enclosures may be slippery. The floor should be skid resistant. Bathers should use care when entering and leaving.
- C) The steam head is hot. Bathers should not touch the steam head and avoid contact with steam near the steam head.
- D) Prolonged use of the steam bath can excessively raise the internal human body temperature and impair the body's ability to regulate its internal temperature (hyperthermia). Limit the use of steam to 10 – 15 minutes until you are certain of your body's reaction.
- E) Excessive temperatures have a high potential for causing fetal damage during the early months of pregnancy. Pregnant or possibly pregnant women should consult a physician regarding correct exposure. Obese persons and persons with a history of heart disease, low or high blood pressure, circulatory system problems, or diabetes should consult a physician before using the steam bath.
- F) Persons using medication should consult a physician before using a steam bath since some medication may induce drowsiness while other medications may affect heart rate, blood pressure and circulation.
- G) The Facility manager should fully understand the causes, symptoms, and effects of hyperthermia which may be described as follows: Hyperthermia occurs when the internal temperature of the body reaches a level several degrees above the normal body temperature of 98.6° F. The symptoms of hyperthermia include an increase in the

internal temperature of the body, dizziness, lethargy, drowsiness, and fainting. The effects of hyperthermia include:

- 1) Failure to perceive heat.
- 2) Failure to recognize the need to exit the steam bath.
- 3) Physical inability to exit the steam bath.
- 4) Unawareness of impending risk.
- 5) Fetal damage in pregnant women.
- 6) Unconsciousness.

**WARNING:** The use of alcohol, drugs, or medication can greatly increase the risk of hyperthermia.

**II. Warning Sign Installation:**

The warning sign shown below and provided with the generator **MUST** be permanently installed on the steam room door or the wall immediately adjacent to the steam room.



## WARNING

### REDUCE THE RISK OF OVERHEATING AND SCALDING

1. EXIT IMMEDIATELY IF UNCOMFORTABLE, DIZZY, OR SLEEPY. STAYING TOO LONG IN A HEATED AREA IS CAPABLE OF CAUSING OVERHEATING.
2. SUPERVISE CHILDREN AT ALL TIMES.
3. CHECK WITH DOCTOR BEFORE USE IF PREGNANT, DIABETIC, IN POOR HEALTH, OR UNDER MEDICAL CARE.
4. BREATHING HEATED AIR IN CONJUNCTION WITH CONSUMPTION OF ALCOHOL, DRUGS, OR MEDICATION IS CAPABLE OF CAUSING UNCONSCIOUSNESS.
5. DO NOT CONTACT STEAM HEAD OR STEAM AT THE STEAM HEAD.

### REDUCE THE RISK OF SLIPPING AND FALL INJURY

1. USE CARE WHEN ENTERING OR EXITING THE STEAM ROOM, FLOOR MAY BE SLIPPERY.

NOTE: FOR ADDITIONAL SAFETY CONSIDERATIONS SEE OWNERS MANUAL.

Pre-Installation

Models: HC-9 thru HC-18

The Heavy Commercial steam generator (HC-9 thru HC-18) comes from the factory assembled, carefully wired, and tested. Please read all instructions before installing or servicing.

**IMPORTANT:**

1. All Plumbing and Electrical work must conform to local and national codes.
2. All power must be OFF to the steam generator when installing or servicing the unit.
3. Do not use or install unauthorized components, accessories or products on the generator or its' piping.

**III. Pre-Installation:**

The following general information should be used in conjunction with your architect, designer and contractor in providing a suitable and safe steam room environment for the steam bathers.

- A) Insure that the model steam generator unit purchased is sized adequately for your steam room.

**IMPORTANT:** Refer to the specification plate affixed to the cabinet of the steam bath generator.

- B) Be sure to have the proper electrical supply. Determine proper size of wire, voltage, amperage, and phase for the steam generator based on the specification plate attached to the generator and the chart in the back of this manual.
- C) Provide an inline fuse/circuit breaker as required sized in accordance with specification plate. Do not install a GFI Ground Fault Interrupter to this equipment.
- D) Select a location to install the generator to allow sufficient room (See Access Area Requirements) for access to the unit in the event service is required. Select a clean dry indoor location protected from freezing. Do not store flammable materials such as gasoline, thinners, paints,

etc. in the same area as the steam generator. Do not store corrosive materials such as chlorine near the steam generator.

- E) For safe low temperature draining (blow down) of the steam generator it may be necessary to drain into an ASME blow down tank. If required additional space for the tank will be necessary. Consult with your architect or licensed plumber. The blow down process can potentially dump boiling water down the drain and damage the drainage system.
- F) The steam generator should be located as close as possible to the steam room. If the steam generator is more than ten feet from the steam head, insulate the steam pipe with appropriate pipe insulation rated for a minimum of 212°F.
- G) The serial number plate should be visible.
- H) The steam room must be completely sealed on all sides, top and bottom. Floor, walls, and ceiling should be completely covered with waterproof material. Floor and bench materials must be slip resistant.
- I) Provide a floor drain inside the steam room for condensate run-off and steam room cleaning.
- J) Only water tight lighting fixtures approved for the application should be used.

Figure 1 - Dimensional Drawing for Heavy Commercial Steam Generator (HC-9 thru HC-18)

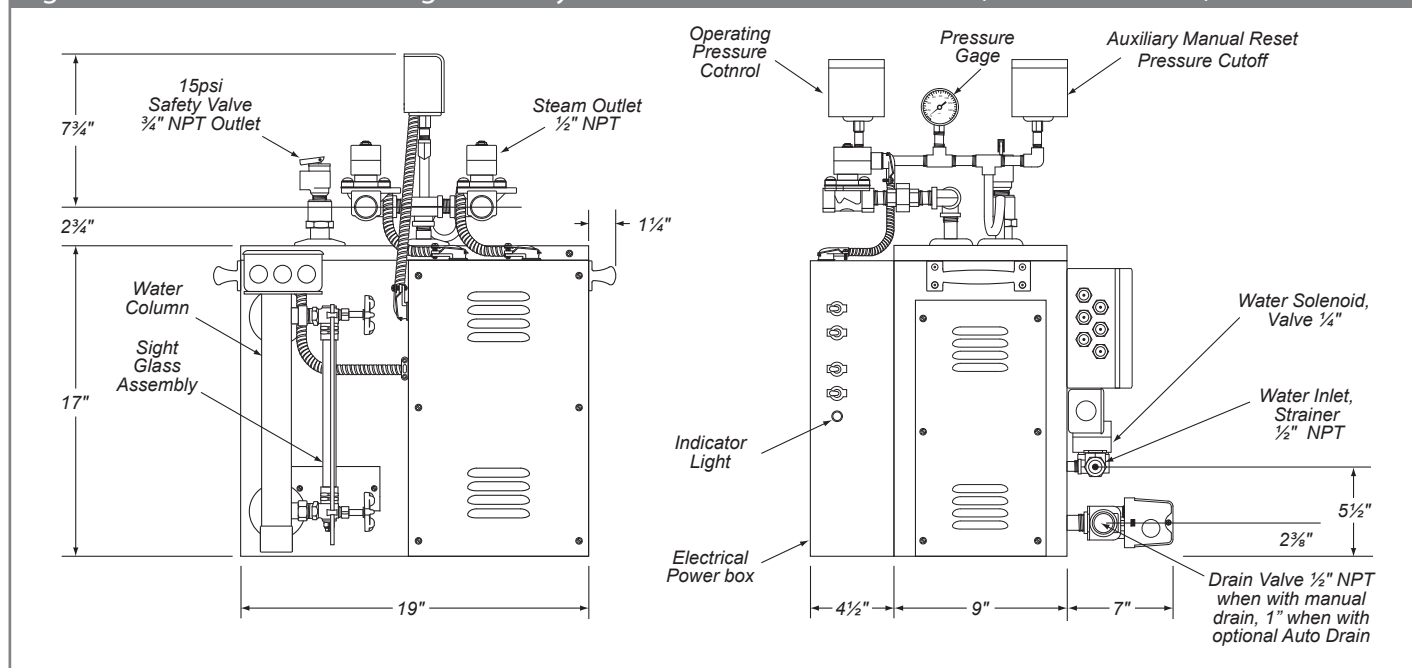

Rough-In

IV. Rough-In:

A) Plumbing Rough-In:

The heavy Commercial "HC" Steam Generator requires the following connections: 1/2" NPT piping for the water inlet, 3/4" copper tubing for steam outlet, and 3/4" NPT safety valve should be piped to an indirect waste line. A 1/2" drain line for a manual drain or a 1" drain line for an optional auto blow down assembly must be provided to route to an indirect waste.

**NOTE:** Location of the steam generator should be placed where the ambient temperature range is: 40°F to 104°F.

- 1) Rough-in a 1/2" water line from a cold water pipe. Provide a local shut-off valve.
- 2) Rough-in the steam line using 3/4" copper tubing. Do NOT use iron or galvanized pipe, it will rust and discolor wall of steam room. For a steam line that is longer than 10 feet use an appropriate pipe insulation rated for a minimum of 212°F. The steam head should be located approximately 18" above the floor and as far from the bather as possible. Do NOT install shut-off valves in this line. Do NOT create traps or valleys in this line which would trap condensation and block the flow of steam.
- 3) Rough-in a 1/2" drain line for a manual drain or a 1" drain line for an optional auto blow down assembly and provide for an indirect waste, to be used for draining steam generator. The indirect drain must be in accordance with local plumbing codes.

4) Rough-in a drain line using 3/4" pipe routed to an indirect waste from the Safety Relief valve. The discharge end of this pipe must not be restricted in any way. It must be piped in a way that would safely discharge steam and/or boiling water in the event of a failure. Always follow local plumbing codes.

B) Electrical Rough-in:

- 1) Route power supply cable to the location where the steam generator will be installed.
- 2) Route control cables as described in the Digital Command Center.

Figure 2 - Cables

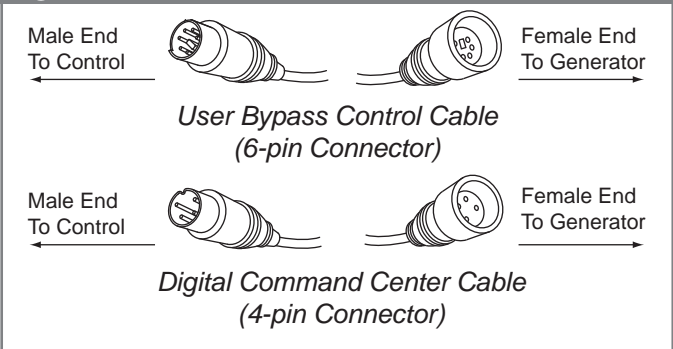
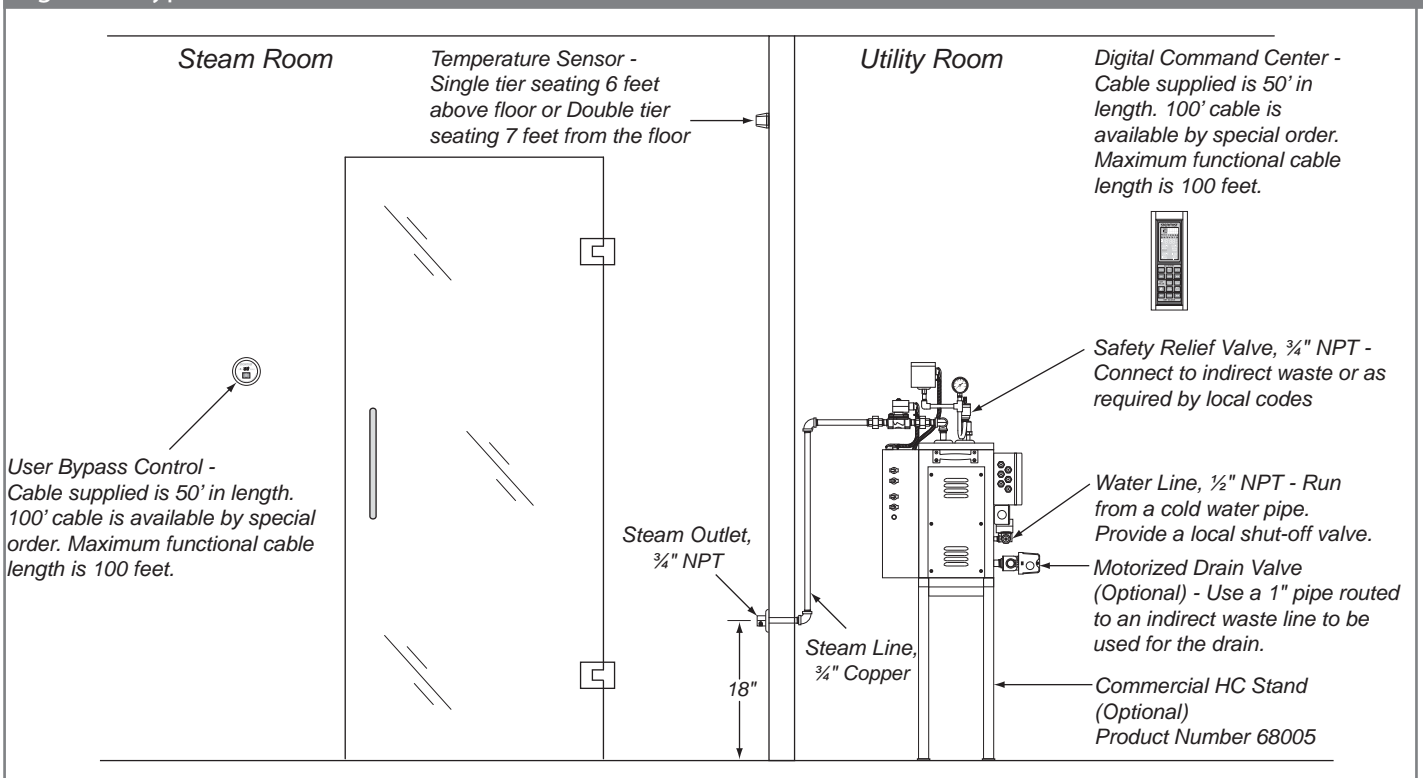

Figure 3 - Typical Steam Generator Installation



## C) Digital Commercial Control Package rough-in:

The DCCP is factory wired for either one or two steam rooms. The following installation instructions are typical for both room installations. **IMPORTANT:** The command center cable, USER BYPASS CONTROL cable and sensor cable are not the same and must not be confused. Also the cables must be routed in the proper direction.

- 1) Digital Command Center rough-in: Route the command center cable in the proper direction from the generator to the selected dry mounting location convenient to the facility operator. Make sure the generator end of the cable is located near the generator mounting location and the control end is located near the control mounting location. Important: the cable is 50' long. 100' cable is available by special order. Maximum functional cable length is 100 feet.

- 2) USER BYPASS CONTROL: Route the USER BYPASS CONTROL cable in the proper direction from the generator to the selected location outside the steam room door. Make sure the generator end is located near the generator mounting location and the control end is located near the control mounting location. Important: the cable is 50' long. 100' cables are available by special order. Maximum functional cable length is 100 feet.

- 3) Room Temperature Sensor: Route the temperature sensor cable in the proper direction from the generator to the selected location inside the steam room. For sensor installation and location, see Figure 3. Make sure the generator end is located near the generator mounting location and the sensor end is located near the sensor mounting location. Important: the cable is 50' long. 100' cables are available by special order. Maximum functional cable length is 100 feet.

## V. INSTALLATION

- A) Plumbing Installation: Care must be taken when installing the steam generator. Leave proper access for servicing (See Installation Area Requirements). (Refer to Figure 2 for typical steam generator installation.) **CAUTION:** The steam generator is designed to be used ONLY in an upright and level position; to do otherwise would damage the unit and void the warranty. For convenient access mount the steam generator on the optional Steamist stand designed specifically for the steam generator.

- 1) Water supply: Purge the water supply line before connecting to the steam generator. In areas where high water pressure may be a problem a water hammer arrestor should be installed.
- 2) Steam line: Connect the steam line from the previously roughed-in location to the steam solenoid valve on the generator marked "steam outlet." If the generator is equipped to provide steam to two rooms care must be taken to make sure the proper steam solenoid is piped to the proper room.
- 3) Safety Line: Connect the 3/4" NPT safety valve into the previously installed indirect waste line.
- 4) Optional automatic blow down: Pipe into the 3/4" indirect waste line.
- 5) In the steam room, place the center of the escutcheon onto the steam pipe and screw the steam head into place. Care must be taken not to scratch the steam head or escutcheon with a wrench. Be sure the steam slot in the steam head is facing down.
- 6) The steam, safety, and drain pipes become hot during operation and should be insulated with appropriate rated pipe insulation to protect against accidental contact.

- B) Electrical Installation: **WARNING ALL POWER TO THE STEAM GENERATOR MUST BE TURNED OFF.**

- 1) Locate and remove six (6) screws securing the access cover to the gray electrical power box. (See Figure 1.)
- 2) Locate appropriate knockout found on top of the gray

electrical power box. Mount a proper strain relief into knockout hole.

- 3) Strip back the power cable's outer insulation jacket twelve inches and insert into gray electrical power box. Strip back insulation 1/2" from the incoming wires: single phase (two power and one ground). 3 phase (three power and one ground).
  - 4) Insert ground wire into grounding lug located on the left side wall of the gray electrical power box. **CAUTION:** insure ground wire does not come in contact with live electrical connections.
  - 5) Locate power block found in upper part of gray electrical power box. Insert power wires into proper power lug terminals on top of the block and secure.
- C) Aroma Pump Option: The aroma pump requires a separate 15 amp 120 volt branch circuit to be connected to the receptacle box located on the side of the generator (see wiring diagram on page 11). This is only necessary to run the aroma pump and is not needed if the pump is not used. To connect the power, remove the cover of the receptacle box. Select a convenient knock out to route the 15 amp 120 volt line into the box. Connect the white pigtail wire to the neutral, the black pigtail wire to the hot wire and ground the box. Replace the cover. Plug in the pump into the appropriate receptacle depending on which room the pump is connected to.

**NOTE:** The pump will only pump when the appropriate room control is in the MAX mode, the ambient room temperature of that room is above the IDLE setting and the steam valve for that room is on. This feature reduces oil consumption by limiting the pumping to the max mode only. Maximum economy of oil consumption can be realized by programming the DCCP to remain in idle mode throughout the day. If programmed this way the oil will only be dispensed when a steam bather presses the button on the user control outside the steam room switching the steam bath to MAX mode for a preset time defined by the manager (recommended setting is 10 minutes). Programmed this way the oil is only pumped on the demand from the user and is a substantial cost savings (See Operating Instructions page 9).

**VI. Digital Command Center Installation:**

**WARNING:** All the electrical power to the steam generator **MUST** be turned OFF before proceeding with installation.

- A) CONTROL MODULE comes factory wired for either one or two steam rooms. The following installation instructions are typical for both room installations. The configuration for one or two room is set at the factory. When the generator is configured for two rooms (SRP-Second Room Package must be ordered) it will have 2 room temperature sensors (one per room), two electric steam valves, two USER BYPASS CONTROLS, and two steam heads. The electric steam valves will be labeled 1 and 2. The connections for the sensors, USER BYPASS CONTROL(s), and aroma pumps, will all be labeled for room 1 and room 2. It is very important to pay special attention not get the connection to room 1 and room 2 crossed. This will be very difficult to troubleshoot. If the generator is configured for one room there will not be any special markings.
- B) USER BYPASS CONTROL(s): The USER BYPASS CONTROL should be located outside the steam room door convenient to the bather. This control gives the bather limited control of the steam room. The system will operate without this control but this function is lost. See the operating instructions for further information on this function. Route the USER BYPASS CONTROL wire from the selected mounting area to the control module on the steam generator. The USER BYPASS CONTROL mounts to 2-1/8" or 55 mm round hole in the wall.
- C) DIGITAL COMMAND CENTER is intended to be used solely by the manager. It should be located at a conve-

nient height for programming. It may be mounted on the wall of the utility room near the steam generator, in the manager's office, or the front desk. The factory supplied wire is 50 feet long, therefore DCC must be located within its reach. **IMPORTANT:** The digital command center is unique and not to be confused with the USER BYPASS CONTROL wires or the sensor wires. The Digital Command Center uses a 4 wire connector, the USER BYPASS CONTROL uses a 6 wire connector and the room sensor uses a 2 wire connector. Route the Digital Commander Center wire from the selected mounting location to the control module located on the steam generator. The Digital Command Center mounts to a hole in the wall 2-1/2" w x 7-7/8" h.

- D) Room Temperature Sensor(s): The room temperature sensor is required for operation. The sensor must be located in the steam room approximately six feet above the floor and never closer than one foot to the ceiling or the corner of the room. Route the cable from this location to the control module on the steam generator. The sensor mounts to a 5/8" hole in the wall.

Figure 4 - Sensor Installation - Inside Steamroom

**NOTE:** Location of the sensor is as follows:  
 a) Single tier seating - 6 feet above floor.  
 b) Double tier seating - 7 feet above floor.

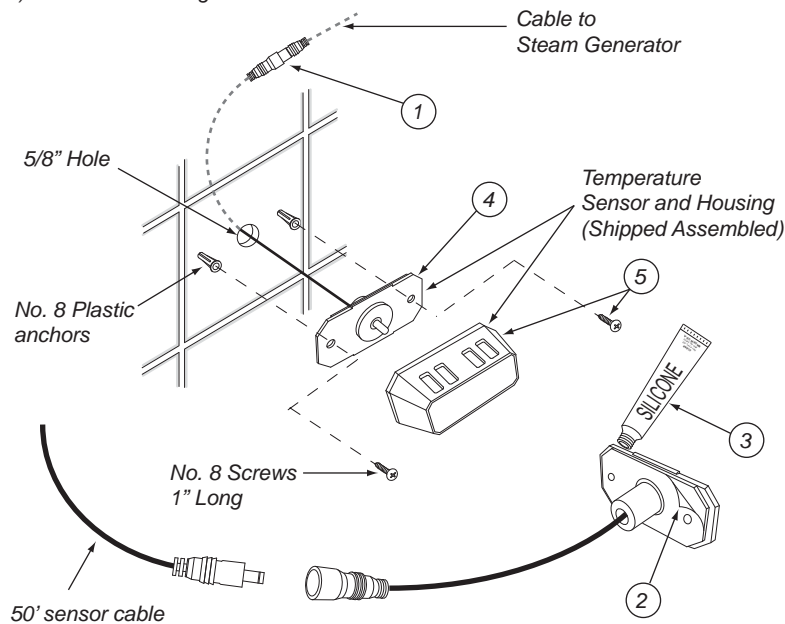

**STEPS TO INSTALL SENSOR:**

- 1) Take new sensor assembly and connect to 50' sensor cable. Please observe polarity of the 50' cable. Make sure the male end of the cable is routed toward the sensor in the steam room.
- 2) Peel off adhesive backing from sensor.
- 3) Carefully apply silicone sealant around rear edge.
- 4) Feed wires back into wall and press sensor firmly to wall (be careful to align plate holes with anchor holes).
- 5) Install screws, and snap chrome cover back into place.
- 6) Temperature sensor assembly must form a 100% water tight seal to the wall using silicone supplied.

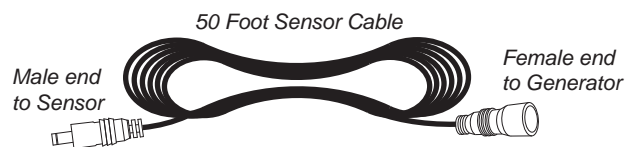



### VII. Digital Commercial Control Package Operation:

This control is designed to maximize energy savings by allowing the facility manager set a lower operation temperature called IDLE TEMP and also satisfy the steam bather with the ability to by-pass this feature on demand by pressing the USER BYPASS CONTROL button. Unlike a typical 24/7 timer which has only an ON or OFF mode, the Digital Command Center has three modes MAX, IDLE and OFF. MAX is the normal ON mode reserved for peak hours of use when the steam room is held at the optimum steam bath temperature. IDLE mode is the energy saving mode. IDLE is set below the MAX temperature and provides a significant energy savings. As needed, the steam bather can easily switch to the MAX setting by pressing the button on the USER BYPASS CONTROL.

- A) **USER BYPASS CONTROL:** The USER BYPASS CONTROL button is only functional during the IDLE mode. In the IDLE mode the USER BYPASS CONTROL, typically mounted at the entrance to the steam room, is waiting for the user to press the button and select the MAX mode. IDLE mode is indicated on the USER BYPASS CONTROL by one lit bar. Pressing the USER BYPASS CONTROL button starts the MAX CYCLE TIMER and immediately begins to heat the room to the MAX setting. This temporary MAX CYCLE TIMER is programmable up to 60 minutes by the facility manager. MAX TEMP mode is indicated by all bars lit. When the Digital Command Center is set to MAX TEMP the USER BYPASS CONTROL icon displays max (all bars lit). In the MAX TEMP mode the USER BYPASS CONTROL buttons do not function. When the DIGITAL COMMAND CENTER is in the OFF mode the USER BYPASS CONTROL icon will be off (no bars lit) and the user buttons do not function.
- B) **Programming the DIGITAL COMMAND CENTER** can be broken down into 3 separate sections, SET EVENT, SET VALUE, and SET CLOCK. The buttons on the control are grouped accordingly. SET EVENT is used to set the time and day that a particular mode (MAX, IDLE, or OFF) is to begin. SET VALUE is intended to set the MAX and IDLE temperature as well as the MAX CYCLE TIMER. The SET

CLOCK section is only for adjustment of the current time and day. The DIGITAL COMMAND CENTER display light comes on when any button is pressed. The light will remain on for 5 minutes after the last button is pressed.

- 1) **SET CLOCK:** The SET CLOCK section of the Digital Command Center is used exclusively for setting the current time and day. It is a convenient place to make changes for daylight savings time without having to reprogram other settings. The clock has a battery backup in the Control Module that will keep time for up to one year with no power.
  - (a) **DAY Setting:** Press the lower DAY button to toggle the current day of the week.
  - (b) **HOUR Setting:** Press the lower HOUR button to select the current AM or PM hour and the correct hour will be displayed.
  - (c) **MINUTE setting:** Press the Lower MINUTE button until the correct minute is displayed.
- 2) **SET VALUE:** The SET VALUE section of the keypad is used to program the following 4 parameters:
  - (a) **MAX1 TEMP** is used to set the maximum desired operating temperature of the steam bath. It is set by pressing the button until the preferred maximum temperature is displayed. *Note: The MAX TEMP cannot be set lower than the IDLE TEMP. Selection of the MAX TEMP setting is at the discretion of the facility manager.*
  - (b) **MAX2 TEMP** (only available with SRP) is used to set the desired operating temperature of a second steam room. It is programmed the same as MAX1 TEMP.
  - (c) **IDLE TEMP** is used to program a lower temperature setting during periods of less frequent usage. It is set by pressing the button until the desired set-back temperature is displayed. The feature can be disabled by setting it to 00. The IDLE TEMP cannot be set higher than the lowest MAX TEMP value.

Figure 5 - User Control Panel

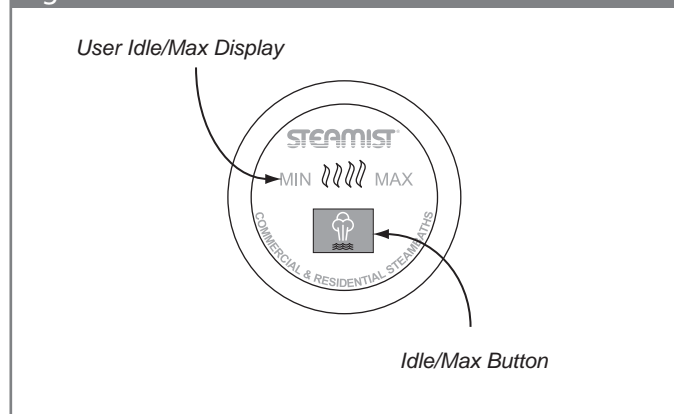

(d) *MAX CYCLE TIMER* is used to set the duration that the system will be in *MAX TEMP* mode after the *USER BYPASS CONTROL* button is pressed in. It is set by pressing the corresponding button on the Digital Command Center. Each time the button is pressed the minutes will increase in one minute increments from “:00” to “:60”. If the *MAX CYCLE TIMER* is programmed to “:00”, this feature will be disabled and the *USER BYPASS CONTROL(S)* will be disabled.

(e) Degree °C or °F change is made by placing a jumper over the CN109 pins for °C or by removing it for °F (Jumper not included). The power must be OFF when making this change. See Command Module on Wiring Diagram page 11.

Figure 6 - Main Control Panel

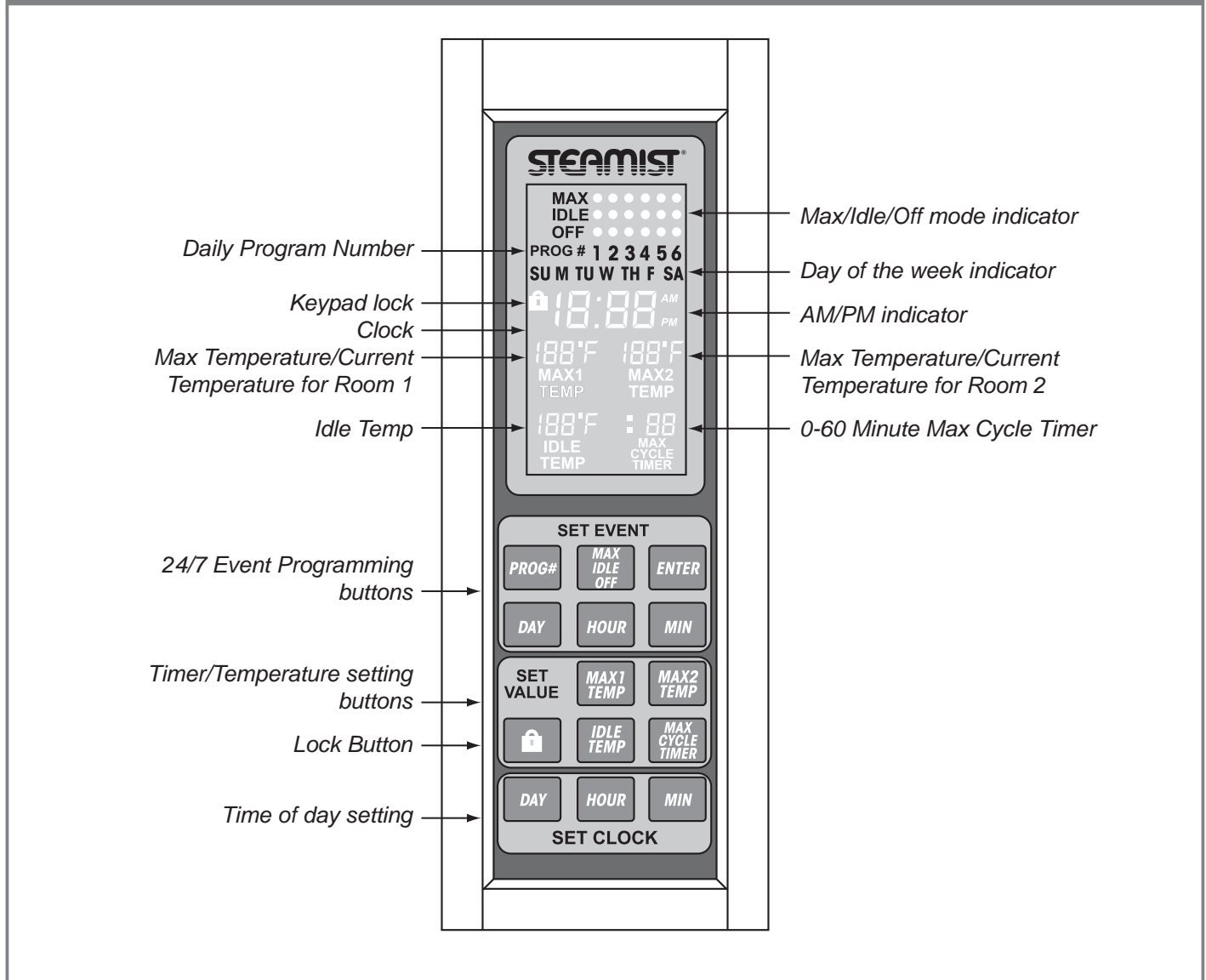

3) **SET EVENT**: Before programming the **SET EVENT**, it is necessary to determine the hours the steam bath will operate and in which mode. Each day of the week can have up to six events programmed. The chart on the following page will help organize your

plan for the **SET EVENT** function. The top 2 sections of the chart are filled in with 2 examples

Digital Commercial Control Package Operation

**EXAMPLE 1** shows the club opening at 7AM. Assuming it is not busy the first hour so the mode is selected as IDLE. Then at 8AM it gets busy and the program switches to MAX. At 10AM it slows down again and the control switches back to

IDLE. Then at 3PM it gets busy again and switches to back to MAX. At 7PM we switch back to IDLE and 10PM the club closes.

PROG #		1	2	3	4	5	6
TIME		7:00AM	8:00AM	10:00AM	3:00PM	7:00PM	10:00PM
EXAMPLE 1	MAX		X		X		
	IDLE	X		X		X	
	OFF						X

**EXAMPLE 2** shows the club opening a 7AM and set to IDLE all day until 10PM when the club closes. This would yield maximum energy savings and is the recommended program. At any time the system is in IDLE mode the user can activate

the MAX TEMP mode by pressing the USER BYPASS CONTROL button.

Photo copy the chart and use it as a work sheet to plan you settings:

PROG #		1	2	3	4	5	6
TIME		7:00AM	8:00AM	10:00AM	3:00PM	7:00PM	10:00PM
EXAMPLE 2	MAX						
	IDLE	X					
	OFF						X

PROG #		1	2	3	4	5	6
TIME							
SU	MAX						
	IDLE						
	OFF						
TIME							
MO	MAX						
	IDLE						
	OFF						
TIME							
TU	MAX						
	IDLE						
	OFF						
TIME							
WE	MAX						
	IDLE						
	OFF						
TIME							
TH	MAX						
	IDLE						
	OFF						
TIME							
FR	MAX						
	IDLE						
	OFF						
TIME							
SA	MAX						
	IDLE						
	OFF						

## Digital Commercial Control Package Operation

- 4) *Programming SET EVENT: To program the SET EVENT section, first press the PROG# button on the Digital Command Center. The display will flash the current program number and show the start time of that program. The program can only be changed while flashing. To enter a new program, first press the DAY button in the upper SET EVENT section to choose the individual day or a block of days (i.e. M-TU-W-TH-F, or SU-M-TU-W-TH-F-SA). With the proper day(s) selected, set start time for program 1 using the upper HOUR and MIN buttons. Be sure to select the proper AM or PM hour. Then press the MAX/IDLE/OFF button to choose the mode for program 1. Program 1 is complete. Press PROG# button to get to program 2. Enter the start time of program 2 and select the mode. You are only programming the start time of each program. The end time is automatically the start time of the next program. The last program entered is limited to 11:59PM. If the facility operates beyond midnight, program 1 of the next day must be set to 12:00 AM for continuous operation. Follow the same process for all the programs and days of the week. To exit the programming mode, press the ENTER button or wait 30 seconds and it will stop blinking and your changes will be saved. The DIGITAL COMMAND CENTER needs a minimum of two programs per day to function as shown in EXAMPLE 2. The first must be IDLE or MAX and the last program must be OFF mode. Note: Programs 1 through 6 are sequential and therefore it will not be possible to set a new program before the end of the previous program.*
- (a) *Programming Tip: To modify an existing program press the PROG# button and the upper DAY button to get to highlight the program you want to change. Then modify the setting with the appropriate button. Entries will be saved automatically in 30 seconds or by pressing the enter button.*
- (b) *Programming Tip: If the facility operates on nearly the same schedule every day, it may be easier to program all seven days to the same common program and then go back and program Sunday to be off if the facility is closed that day.*
- (c) *Programming Tip: You can review your program by pressing the PROG# button and toggling through the programs and toggling through the days of the weeks, and observing the time settings. If you made no changes simply press the enter button to return to normal or it will return in 30 seconds.*
- (d) *Programming Tip: When reviewing the program and a block of days are selected, if all the individual programs for those days do not match, the clock will display --:--. This is normal and any adjustments made at this time will reprogram all days selected to match the new entry.*
- 5) *Manager lock function: The Digital Command Center has a locking feature that prevents any setting to be changed when locked. To lock the control, press the lock button, the lock icon will flash for up to 30 seconds. While the icon is flashing, press any three consecutive buttons, and then press the lock button again to confirm. The three consecutive buttons pressed are the password. The system control will be locked and the lock icon will be on steady. To unlock, press the lock button and then press the same three consecutive buttons as the previous password, the system will be unlocked and the lock icon will disappear. If the password is lost or forgotten, it can be reset. This will require two people. Turn off the main power (circuit breaker), have a second person then press and hold the lock button on the Digital Command Center while the first person turns the power back on. The system will be unlocked. Also see the reset section for an alternate method (step 11).*
- 6) *Temporary Mode setting: By pressing IDLE/MAX/OFF button on the Digital Command Center you can temporarily change the current mode (IDLE/MAX/OFF). This is only a temporary change until the next programmed event.*
- 7) *Auto-Blow Down: The optional auto-blow down becomes active in the OFF mode. When first entering OFF mode, the steam valves will deactivate and the generator will continue to maintain normal pressure. After 5 minutes the generator will shut down and the drain will open. Boiling water will exit under pressure and the water valve will turn on to help flush the generator. After 2 minutes the drain will close and the generator will refill. After a total of 7 minutes the generator is ready to start a new cycle. If the facility is operated 24 hours a day, a 7 minute OFF mode should be programmed in to allow for a proper drain cycle. In areas where the water is hard, a second drain cycle can be programmed by adding an extra 7 minute off mode program.*

minute OFF mode during an "Off-Peak" daytime period. **IMPORTANT:** Due to possible code violations or damage to the building drainage system the hot boiling water exiting in this process may require a Blow-Down Tank. Consult with your licensed contractor. Blow-Down tanks may be purchased separately.

- 8) **Steam Control:** The steam valve(s) are controlled according to the room temperature sensor(s) and the programmed mode. When the room temperature is lower than the set temperature by one degree the steam valve will turn on. When it reaches the set temperature it turns off. If for some reason the room temperature exceeds the MAX TEMP setting (of either room) by more than 10 degrees the Digital Command Center will turn off the generator until that room temperature drops to 1 degree below the set temperature.
- 9) **Aroma Control:** There are two aroma control relays (one for each room) located in the Command Module on the generator. These relays can be used with most aroma pumps available. The relays are programmed to conserve aroma therapy oil. The relays are only on when the following conditions are met. The program for that room must be in the MAX mode, the steam valve for that room must be on and

the temperature in that room must be above the IDLE setting. When all these conditions are met, then the aroma relays will energize.

- 10) **Fahrenheit and Celsius:** The Fahrenheit or Celsius temperature can be selected by changing a jumper in the Command Module (CN109). When it is not connected (open circuit), it will be Fahrenheit. When it is connected, it will be Celsius. The Jumper must be switched with power off (See wiring diagram on page 11).
- 11) **Reset Feature:** If it is ever necessary to reset all the programs and start over press and hold the PROG# button and the lower MIN button for five seconds simultaneously. This will reset every setting in the Command Center. This process can also be used to unlock the control if the password is lost or forgotten.

Specifications Chart

Model No.	Product No.	KW	Max. Cu. Ft.	Volts/Phase/Amps	Line Fuse	Water Inlet	Steam Outlet	Dimensions	Shipping Weight
<b>HC-9</b>	60900	9	400	240/1/38	50	1/2" NPT	3/4" NPT	22-1/2"x19"x28"	140 lbs.
	60901			208/1/43	60				
	60902			240/3/22	30				
	60903			208/3/25	35				
	60904			480/3/11	15				
<b>HC-12</b>	61200	12	500	240/1/50	70	1/2" NPT	3/4" NPT	22-1/2"x19"x28"	150 lbs.
	61201			208/1/58	80				
	61202			240/3/29	40				
	61203			208/3/33	45				
	61204			480/3/15	20				
<b>HC-15</b>	61500	15	620	240/1/63	80	1/2" NPT	3/4" NPT	22-1/2"x19"x28"	150 lbs.
	61501			208/1/72	90				
	61502			240/3/36	45				
	61503			208/3/42	60				
	61504			480/3/18	25				
<b>HC-18</b>	61800	18	740	240/1/75	100	1/2" NPT	3/4" NPT	22-1/2"x19"x28"	150 lbs.
	61801			208/1/87	110				
	61802			240/3/43	60				
	61803			208/3/50	70				
	61804			480/3/22	30				

Figure 7 "HC" Wiring Diagram with Options

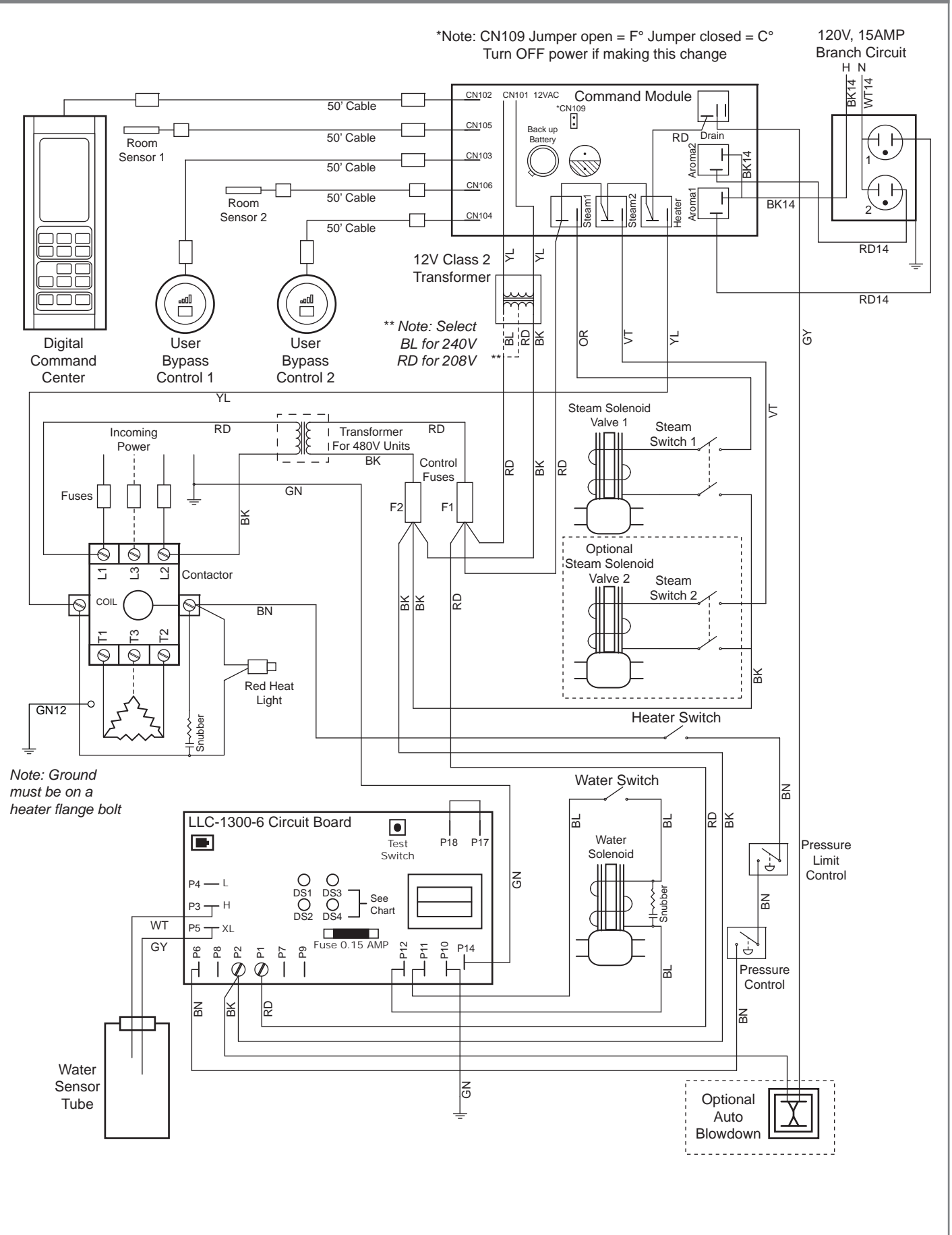



**LIMITED WARRANTY**

STEAMIST, INC. hereby warrants that its Steamist generators Models HC-9, HC-12, HC-15, and HS-18 are free from all defects in workmanship and materials for one (1) year from the date of purchase.

This warranty does not extend to damage caused by improper or negligent installation or use, or for any repairs attempted by any person other than an authorized Steamist dealer and shall be limited to the repair or replacement of defective parts by STEAMIST or its authorized dealers. After the unit has been disconnected and returned to STEAMIST's plant or to one of its authorized dealers warehouses, said repairs shall be without charge if within ninety (90) days of the date of purchase. After the expiration of ninety (90) days for the duration of the limited warranty period, there shall be a reasonable charge for labor incurred in connection with the repair or replacement indicated above.

*Freight:* Within the first ninety (90) days and with prior company approval, Steamist will pay all freight charges on items covered under our warranty. Thereafter and until the end of the warranty period, and with prior company approval, the customer is required to ship freight prepaid to Steamist's factory and Steamist will then ship freight prepaid back to customer.

This is not a service contract and this warranty does no include regular maintenance, cleaning or periodic check-ups, which are the sole and exclusive responsibility of the purchaser and are required as a condition of keeping this limited warranty in full force and effect.

This warranty shall not become effective unless the attached registration of Warranty is completed and returned to STEAMIST within fifteen (15) days of the date of installation.

This warranty is non-transferable and shall extend only to the original purchaser who shall have been named in the Registration of Warranty.

This warranty is void if any of the following should occur:

1. If the serial number has been altered or removed.
2. If the product is modified in any manner which STEAMIST concludes after inspection affects the reliability of the product.
3. If the product has been repaired or serviced by anyone not specifically designated and authorized by STEAMIST.
4. If the product is damaged because it is not operated or installed in accordance with supplied instructions.

The sole responsibility of STEAMIST under this warranty shall be limited to the repair of the product or replacement thereof, including parts, in the sole discretion of STEAMIST INC. The consumer's sole remedy shall be such repair or replacement as is expressly provided herein and under no circumstances shall STEAMIST be liable for any loss or damage be it direct or consequential arising out of the use or inability to use this product.

THE FOREGOING IS IN LIEU OF ALL OTHER WARRANTIES AND SPECIFICALLY EXCLUDES AND DISCLAIMS EXPRESS AND IMPLIED WARRANTIES OF MERCHANTABILITY OR OF FITNESS FOR PARTICULAR USE OF PURPOSE. THERE ARE NO WARRANTIES WHICH EXTEND BEYOND THE DESCRIPTION ON THE FACE HEREOF AND NEITHER STEAMIST NOR ITS DEALERS ASSUMES OR AUTHORIZES ANY PERSON TO ASSUME FOR ANY OF THEM ANY OTHER OBLIGATION OR LIABILITY IN CONNECTION WITH SAID EQUIPMENT.

No warranty whether express or implied is given or made with respect to any accessory supplied by anyone other than STEAMIST.

Purchaser acknowledges that no other representations were made to him or relied on by him with respect to the quality and function of the generators.

**Model No.** \_\_\_\_\_ **Serial No.** \_\_\_\_\_ **Date of Purchase** \_\_\_\_\_